



**KEY FEATURES**

- Enhance real world performance using less space and power compared to adding drive spindles and un-needed capacity
- Up to 50x performance increase in frequently accessed files and data hot spot simulation benchmarks\*
- Substantially reduce latency in small block, random read and intensive environments

Software License Ordering PN	LSI00265
Physical Key Ordering PN	LSI00248
Supported RAID Controllers	MegaRAID SAS 9260-4i MegaRAID SAS 9260-8i MegaRAID SAS 9261-8j* MegaRAID SAS 9260-16i MegaRAID SAS 9280-4i4e MegaRAID SAS 9280-8e* MegaRAID SAS 9280-16i4e MegaRAID SAS 9280-24i4e
Supported Operating Systems	All supported operating systems
Supported SSDs	Please visit <a href="http://www.lsi.com/channel/support/marketing_resources">www.lsi.com/channel/support/marketing_resources</a> for a complete list of tested SSDs.
Max. Number of SSD Disks in a CacheCade Cache Pool	32 SSDs
Max. Number of SSCVD Supported in a Controller	Up to 64 (The total number of HDD VDs plus CacheCade VDs must not exceed 64 as this is the maximum number of VDs supported per 6Gb/s SATA+SAS MegaRAID controller)
Max. CacheCade Capacity per Controller	512GB
Optimum Controller settings for CacheCade Software	Write Policy: Write Back IO Policy: Cached IO Read Policy: No Read Ahead Stripe Size: 64KB

\* These controllers will accept only a software license and are not compatible with the physical hardware key

## LSI™ MegaRAID® CacheCade™ Software

Add one or more SSDs and substantially improve IOPs performance rather than adding more drives to an array

### Improve Application I/O Performance

Interest in solid-state storage has grown rapidly; however, the biggest issue holding back solid-state storage in general purpose servers today is that enterprise-class drives cost at least 10 times as much as conventional hard drives from a price-per-GB perspective. Capitalizing on the performance advantages of solid state drives (SSDs) as well as the cost and capacity advantage of SATA and SAS drives, CacheCade software is designed to allow a server's existing drive volume to utilize SSD technology as a secondary tier of cache to maximize random read performance.

Currently, SAS drives can sustain only a few hundred IOPS while SATA drives reach even less. SSD devices, on the other hand, are capable of delivering IOs per second in the tens of thousands. CacheCade software allows for frequently-read data (hot-spot) to be moved to second tier SSD cache for much faster

retrieval of that data when it is time for it to be re-read. This provides significant performance improvement of 2x to 50x for read-intensive applications such as web, file, SQL, and other transactional server applications.\*

### Cost Optimized SSD Usage

MegaRAID CacheCade software allows customers to blend inexpensive SATA hard disk drives (HDDs) with a small amount of solid state storage capacity to provide a substantial performance boost while avoiding complete 1:1 replacement of SATA HDDs with faster SAS HDDs, adding additional SATA HDDs or moving to an all SSD RAID volume to achieve performance requirements. This combination of HDDs and SSDs as secondary cache helps improve IOPs per dollar, particularly in random read intensive applications. Simply select an SSD(s) and associate it with one or more virtual drives to configure and use CacheCade software.

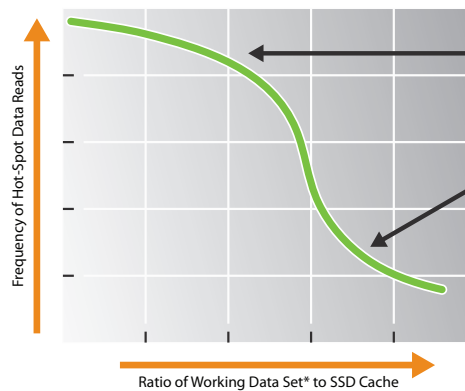

Best suited for applications (such as web and SMB OLTP) that frequently re-read data from a small working data set\*.

Applications with larger active data sets with much more variable I/O size and read/write profiles require additional SSD drives to show similar performance improvement with CacheCade.

\* Working Data Set: A subset of the total stored data actively utilized by an application or applications at a specific point in time. The size of working data set varies from a small portion of the total amount of data stored up to all of the stored data depending on the application and typical usage model.

Figure 1: MegaRAID CacheCade Effectiveness

Figure 2: CacheCade Application Value Opportunity

### Single Cache SSD

- Best suited for small working data set apps (examples: Web Server or Blackberry email server type applications)
- Data is frequently re-read from a relatively small working data set
- Max CacheCade performance boost achieved when working data set fits in SSD cache

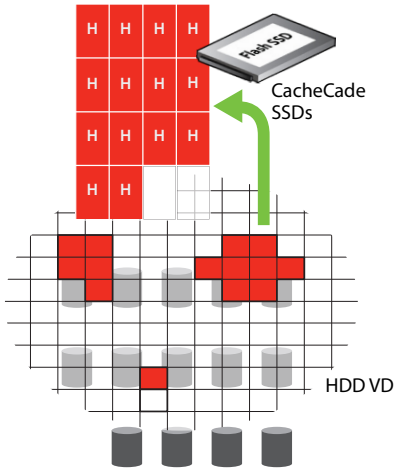

### Multiple Cache SSDs

- Transactional database (OLTP, SQL) and some email applications have larger working data sets that require more CacheCade SSDs to scale performance

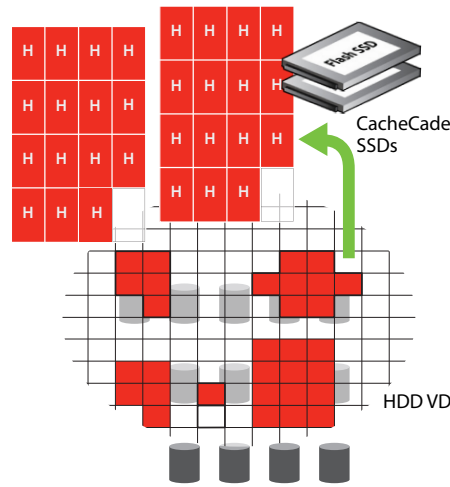

### Multiple Cache SSDs

- Applications with larger active data sets with much wider IO access ranges show less improvement with CacheCade
- Cache hit rates are lower due to heavy percentage of write requests as compared to read requests

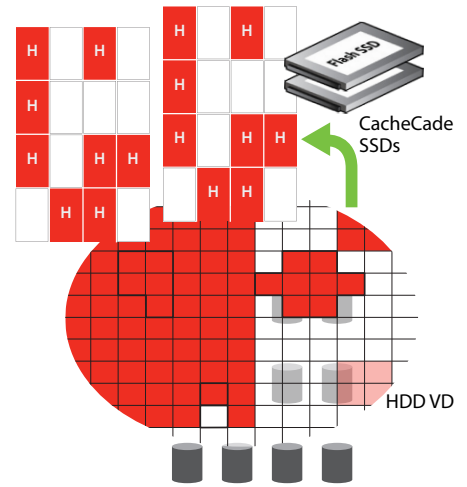

**H** Cache hits to CacheCade SSDs      **■** Read data hot spots or frequently read data

Figure 3: CacheCade Value Proposition

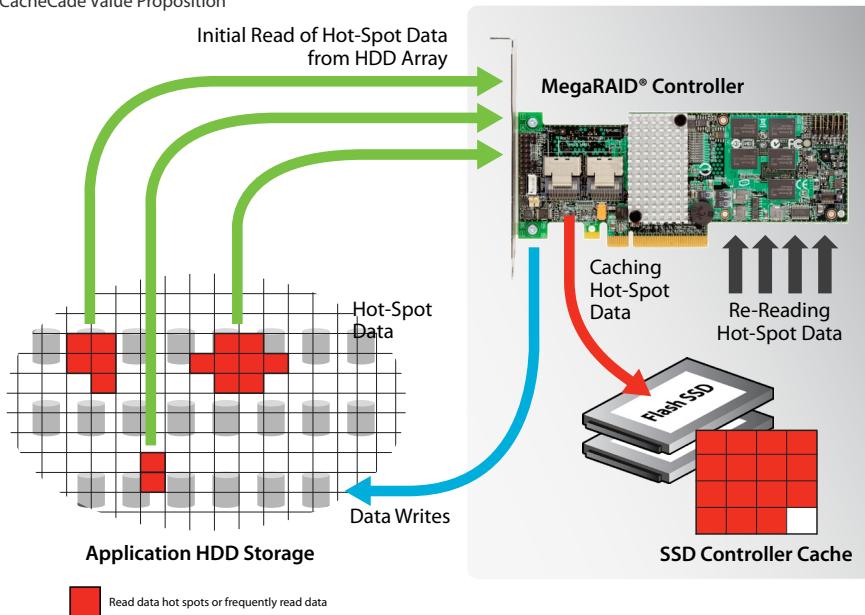

**■** Read data hot spots or frequently read data

### CacheCade Software

Frequently accessed data sets are copied from HDD to lower latencies Flash SSDs to improve system performance in subsequent read requests

**50x Increase on Re-Reads of Hot-Spot Data**

### LSI SSD Guard™ Technology

SSDs are known for their reliability and performance. The LSI SSD Guard technology, that is unique to MegaRAID® controller cards, increases the reliability of SSDs by automatically copying data from a drive with potential to fail to a designated hot spare or newly inserted drive. A predictive failure event notification, or S.M.A.R.T command, automatically initiates this rebuild to help preserve the data on an SSD whose health or performance falls below par. For RAID volumes that are using CacheCade™ software, SSD Guard technology can help ensure that the health and performance of SSDs being used for second tier cache are being monitored in the background.

\* A 14GB volume on a two drive RAID 1 array was used to simulate web server re-read hot spot activity. Using IOMeter version 2006.07.27, a MegaRAID SAS 9260-8e with configuration settings: No Read Ahead, Write Back Cache, 64KB Stripe Size and Direct IO, using firmware version 2.60.03-0778, reached 14,896 IOs per second with CacheCade enabled, compared to 273 IOs per second with CacheCade disabled. This represents an increase of more than 50x.

For more information and sales office locations, please visit the LSI web sites at:

[lsi.com](http://lsi.com)    [lsi.com/channel](http://lsi.com/channel)

LSI, LSI and Design logo, CacheCade, FastPath, MegaRAID, MegaRAID Storage Manager, and SSD Guard are trademarks or registered trademarks of LSI Corporation. All other brand and product names may be trademarks of their respective companies.

LSI Corporation reserves the right to make changes to any products and services herein at any time without notice. LSI does not assume any responsibility or liability arising out of the application or use of any product or service described herein, except as expressly agreed to in writing by LSI; nor does the purchase, lease, or use of a product or service from LSI convey a license under any patent rights, copyrights, trademark rights, or any other of the intellectual property rights of LSI or of third parties.

Copyright ©2010 by LSI Corporation. All rights reserved.  
April 2010

